

AMC 10A 2021 Solutions

Julian Zhang

October 2021

1 Credits

Problems and some solutions courtesy of some cool people on AOPS, you should check them out - here's a list of the problems and links to the solutions: <https://artofproblemsolving.com/community/c2611232>

2 Solutions

1. What is the value of $\frac{(2112 - 2021)^2}{169}$?

(A) 7 (B) 21 (C) 49 (D) 64 (E) 91

Solution: $2112 - 2021 = 91$

$$\frac{91^2}{169} = \frac{91^2}{13^2} = \left(\frac{91}{13}\right)^2 = 7^2 = \boxed{\text{(C)}49}$$

2. Menkara has a 4×6 index card. If she shortens the length of one side of this card by 1 inch, the card would have area 18 square inches. What would the area of the card be in square inches if instead she shortens the length of the other side by 1 inch?

(A) 16 (B) 17 (C) 18 (D) 19 (E) 20

Solution: Notice $6(4 - 1) = 18$, so our answer is $6(4 - 1) = \boxed{\text{(D)} 20}$

3. What is the maximum number of balls of clay of radius 2 that can completely fit inside a cube of side length 6 assuming the balls can be reshaped but not compressed before they are packed in the cube?

Solution: Recall the formula for volume of a sphere is $\frac{4\pi r^2}{3}$. Thus, $\frac{216}{\frac{4}{3} \cdot 2^3 \cdot \pi} \approx \frac{216}{33.5} \approx 6.45$, $[6.45] =$

$\boxed{\text{(D)} 6}$

4. Mr. Lopez has a choice of two routes to get to work. Route A is 6 miles long, and his average speed along this route is 30 miles per hour. Route B is 5 miles long, and his average speed along this route is 40 miles per hour, except for a $\frac{1}{2}$ -mile stretch in a school zone where his average speed is 20 miles per hour. By how many minutes is Route B quicker than Route A?

(A) $2\frac{3}{4}$ (B) $3\frac{3}{4}$ (C) $4\frac{1}{2}$ (D) $5\frac{1}{2}$ (E) $6\frac{3}{4}$

Solution: Recall $t = \frac{d}{s}$.

$$60\left(\frac{6}{30} - \left(\frac{\frac{9}{2}}{40} + \frac{\frac{1}{2}}{40}\right)\right) = 60\left(\frac{6}{30} - \left(\frac{9}{80} + \frac{1}{40}\right)\right) = 60\left(\frac{48-27-6}{240}\right) = \frac{15}{4} = \boxed{\text{(B)} 3\frac{3}{4}}$$

5. The six-digit number $\underline{2} \underline{0} \underline{2} \underline{1} \underline{0} \underline{A}$ is prime for only one digit A . What is A ?

(A) 1 (B) 3 (C) 5 (D) 7 (E) 9

Solution: Using divisibility rules, we can rule out (C) 5 (divisible by 5), (A) 1 and (D) 7 (divisible by 3), and (B) 3 (divisible by 11). Thus, the only correct answer is $\boxed{\text{(E)} 9}$.

6. Elmer the emu takes 44 equal strides to walk between consecutive telephone poles on a rural road. Oscar the ostrich can cover the same distance in 12 equal leaps. The telephone poles are evenly spaced, and the 41st pole along this road is exactly one mile (5280 feet) from the first pole. How much longer, in feet, is Oscar's leap than Elmer's stride?

(A) 6 (B) 8 (C) 10 (D) 11 (E) 15

Solution: $\frac{5280}{41-1} = 132 \implies \frac{132}{12} - \frac{132}{44} = \boxed{\text{(B) } 8}$

7. As shown in the figure below, point E lies on the opposite half-plane determined by line CD from point A so that $\angle CDE = 110^\circ$. Point F lies on \overline{AD} so that $DE = DF$, and $ABCD$ is a square. What is the degree measure of $\angle AFE$?

(A) 160 (B) 164 (C) 166 (D) 170 (E) 174

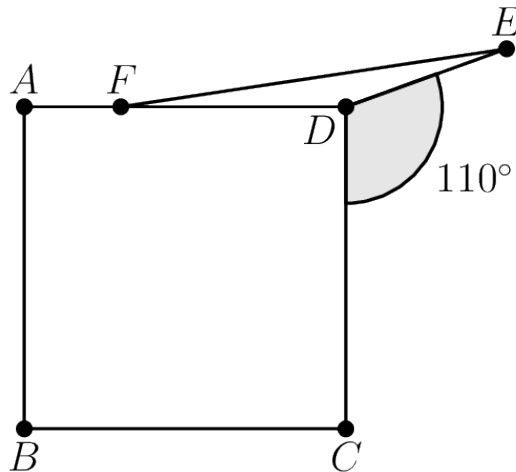

Solution: $\angle FDE = 360^\circ - 110^\circ - 90^\circ = 160^\circ$.

$FD = DE \implies \angle DFE = \angle DEF \implies \angle DFE = \angle DEF = \frac{180^\circ - 160^\circ}{2} = 10^\circ \implies \angle AFE = 180^\circ - 10^\circ = 170^\circ \implies \boxed{\text{(D)}}$

8. A two-digit positive integer is said to be cuddly if it is equal to the sum of its nonzero tens digit and the square of its units digit. How many two-digit positive integers are cuddly?

(A) 0 (B) 1 (C) 2 (D) 3 (E) 4

Solution: Letting the integer be $10a + b$, we have $10a + b = b^2 \implies 9a = b^2 - b \implies 9a = b(b-1) \implies 9 \mid b(b-1)$. The only integer that satisfies this is $89 = 8 + 9^2$, thus $\boxed{\text{(B) } 1}$

9. When a certain unfair die is rolled, an even number is 3 times as likely to appear as an odd number. The die is rolled twice. What is the probability that the sum of the numbers rolled is even?

(A) $\frac{3}{8}$ (B) $\frac{4}{9}$ (C) $\frac{5}{9}$ (D) $\frac{9}{16}$ (E) $\frac{5}{8}$

Solution: To obtain an even sum, the numbers have to either be even and even, or odd and odd.

$$\left(\frac{3}{4}\right)^2 + \left(\frac{1}{4}\right)^2 = \frac{9}{16} + \frac{1}{16} = \boxed{\text{(E) } \frac{5}{8}}$$

10. A school has 100 students and 5 teachers. In the first period, each student is taking one class, and each teacher is teaching one class. The enrollments in the classes are 50, 20, 20, 5, and 5. Let t be the average value obtained if a teacher is picked at random and the number of students in their class is noted. Let s be the average value obtained if a student was picked at random and the number of students in their class, including the student, is noted. What is $t - s$?

(A) -18.5 (B) -13.5 (C) 0 (D) 13.5 (E) 18.5

Solution:: $t = \frac{100}{5} = 20$, $s = \frac{50^2 + 2(20^2) + 2(5^2)}{100} = \frac{3350}{100} = 33.5$, $t - s = 20 - 33.5 = \boxed{\text{(A)} -18.5}$

11. Emily sees a ship traveling at a constant speed along a straight section of a river. She walks parallel to the riverbank at a uniform rate faster than the ship. She counts 210 equal steps walking from the back of the ship to the front. Walking in the opposite direction, she counts 42 steps of the same size from the front of the ship to the back. In terms of Emily's equal steps, what is the length of the ship?
(A) 70 **(B)** 84 **(C)** 98 **(D)** 105 **(E)** 126

Solution: Let x be Emily's speed, y be the speed of the ship, and L be the length of the boat. We now have $210(x + y) = L$ and $42(x - y) = L \implies 210(x + y) = 5L \implies 420x = 6L \implies x = \boxed{\text{(A)} 70}$

Note that you can also use the harmonic mean trick, that is to say that $\frac{2}{\frac{1}{240} + \frac{1}{42}} = \text{(A)} 70$

12. The base-nine representation of the number N is $27,006,000,052_{\text{nine}}$. What is the remainder when N is divided by 5?
(A) 0 **(B)** 1 **(C)** 2 **(D)** 3 **(E)** 4

Solution: Converting to base-10 gives us $N = 2 \cdot 9^{10} + 7 \cdot 9^9 + 6 \cdot 9^6 + 5 \cdot 9^1 + 2 \cdot 9^0$

Notice that $9^{\text{even}} \equiv 1 \pmod{5}$, and $9^{\text{odd}} \equiv -1 \pmod{5}$. Thus, $N \equiv 9 - 7 + 6 - 5 + 2 \equiv 3 \pmod{5} = \boxed{\text{(D)} 3}$

13. Each of 6 balls is randomly and independently painted either black or white with equal probability. What is the probability that every ball is different in color from more than half of the other 5 balls?
(A) $\frac{1}{64}$ **(B)** $\frac{1}{6}$ **(C)** $\frac{1}{4}$ **(D)** $\frac{5}{16}$ **(E)** $\frac{1}{2}$

Solution: Note the only combination that works is 3 white and 3 black balls, thus the probability is $\frac{\binom{6}{3}}{64} = \boxed{\frac{5}{16}}$

14. How many ordered pairs (x, y) of real numbers satisfy the following system of equations?

$$\begin{aligned} x^2 + 3y &= 9 \\ (|x| + |y| - 4)^2 &= 1 \end{aligned}$$

- (A)** 1 **(B)** 2 **(C)** 3 **(D)** 5 **(E)** 7

Solution: Either by bashing or graphing, we get two squares with coordinates $(x, y) \in \{0, 5\}$ and $(x, y) \in \{0, 3\}$ so there are $\boxed{\text{(D)} 5}$ intersection points, including the vertex of the parabola

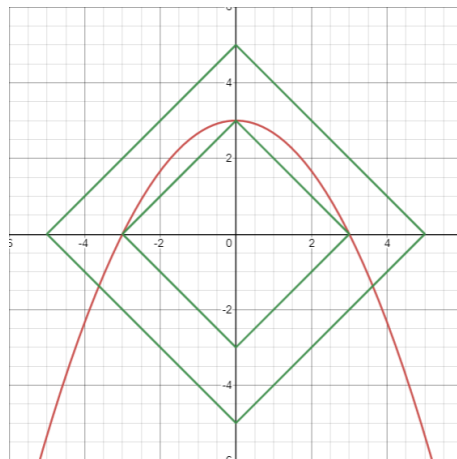

15. Isosceles triangle ABC has $AB = AC = 3\sqrt{6}$, and a circle with radius $5\sqrt{2}$ is tangent to line AB at B and to line AC at C . What is the area of the circle that passes through vertices A , B , and C ?

(A) 24π (B) 25π (C) 26π (D) 27π (E) 28π

Solution: Drawing center O of the circle, we have $\angle ABO = \angle ACO = 90^\circ$ since it's a point of tangency. Note that \overline{AO} is also the diameter of the circumcircle of $\triangle ABC$ since $\angle ABO$ is right, thus

$$d = \sqrt{(3\sqrt{6} + 5\sqrt{2})^2} = 2\sqrt{26}. \quad r = \sqrt{26}, \quad A = \boxed{\text{(C)} 26}$$

16. The graph of $f(x) = \lfloor x \rfloor - \lfloor 1 - x \rfloor$ is symmetric about which of the following? (Here $\lfloor x \rfloor$ is the greatest integer not exceeding x .)

(A) the y -axis (B) the line $x = 1$ (C) the origin (D) the point $\left(\frac{1}{2}, 0\right)$ (E) the point $(1, 0)$

Solution: By plugging in values, we find that any integer $x \leq 0 = -1$, and any integer $x \geq 1 = 1$.

Any non-integer x gives 0, so our answer must be $\boxed{\text{(D) the point}\left(\frac{1}{2}, 0\right)}$

17. An architect is building a structure that will place vertical pillars at the vertices of regular hexagon $ABCDEF$, which is lying horizontally on the ground. The six pillars will hold up a flat solar panel that will not be parallel to the ground. The heights of the pillars at A , B , and C are 12, 9, and 10 meters, respectively. What is the height, in meters, of the pillar at E ?

(A) 9 (B) $6\sqrt{3}$ (C) $8\sqrt{3}$ (D) 17 (E) $12\sqrt{3}$

Solution: Let a, b, c, d, e, f be the heights at the vertices. Note that $a + d = b + e = c + f = S$, and $22 + (S - 9) = a + c + e = b + d + f = (2S - 22) + 9$. Then $S = 26$, and $e = S - 9 = 17$. $\boxed{\text{(D)}}$

18. A farmer's rectangular field is partitioned into 2 by 2 grid of 4 rectangular sections as shown in the figure. In each section the farmer will plant one crop: corn, wheat, soybeans, or potatoes. The farmer does not want to grow corn and wheat in any two sections that share a border, and the farmer does not want to grow soybeans and potatoes in any two sections that share a border. Given these restrictions, in how many ways can the farmer choose crops to plant in each of the four sections of the field?

(A) 12 (B) 64 (C) 84 (D) 90 (E) 144

Solution: Without loss of generality, set the top-left corner to one of the four crops (assume corn). Now, we do casework on the two corners adjacent to the top-left:

Case 1: Two adjacent sections are similar: There are 3 possibilities to fill both (eg. wheat), then 3 ways to fill the bottom-right square (wheat, soybeans, potatoes), giving a total of $3 \cdot 3 = 9$

Case 2: Two adjacent sections are different: There are $3 \cdot 2$ ways to fill the adjacent sections (eg. soybeans and potatoes, note it can't be wheat), then 2 ways to fill the bottom-right square (corn, wheat) for a total of $3 \cdot 2 \cdot 2 = 12$ For our final answer, we have $4 \cdot (9 + 12) = 81 = \boxed{\text{(D)}}$ ways.

19. A disk of radius 1 rolls all the way around the inside of a square of side length $s > 4$ and sweeps out a region of area A . A second disk of radius 1 rolls all the way around the outside of the same square and sweeps out a region of area $2A$. The value of s can be written as $a + \frac{b\pi}{c}$, where a, b , and c are positive integers and b and c are relatively prime. What is $a + b + c$?

(A) 10 (B) 11 (C) 12 (D) 13 (E) 14

Solution: $2(4 \cdot 2(s - 4) + 4(\frac{3 \cdot 4}{4}) + \pi) = 8s + 4\pi$

$$2(8s - 20 + \pi) = 8s + 4\pi$$

$$16s - 40 + 2\pi = 8s + 4\pi$$

$$8s = 40 - 2\pi$$

$$s = 5 + \frac{1}{4}\pi \implies 5 + 4 + 1 = \boxed{\text{(A) 10}}$$

20. How many ordered pairs of positive integers (b, c) exist where both $x^2 + bx + c = 0$ and $x^2 + cx + b = 0$ do not have distinct, real solutions?

(A) 4 (B) 6 (C) 8 (D) 10 (E) 12

Solution: Using the discriminant, we have that $b^2 - 4c \leq 0$ and $c^2 - 4b \leq 0$. When they are equal, we have $(4, 4), (3, 3), (2, 2), (1, 1)$, and we also have $(2, 1), (1, 2)$ for a total of **(B) 6**

21. Each of the 20 balls is tossed independently and at random into one of the 5 bins. Let p be the probability that some bin ends up with 3 balls, another with 5 balls, and the other three with 4 balls each. Let q be the probability that every bin ends up with 4 balls. What is $\frac{p}{q}$?

(A) 1 (B) 4 (C) 8 (D) 12 (E) 16

Solution: There are $\binom{20}{3,5,4,4,4} = \frac{20!}{3!5!4!4!4!}$ ways to choose which balls go into which bins, and $5 \cdot 4 = 20$ ways to choose which bins have 5 and 3 balls. For the case in which every bin has 4 balls, there are $\binom{20}{4,4,4,4,4} = \frac{20!}{4!4!4!4!4!}$ to choose the bins, and no other factor because every bin is symmetric. Thus, the answer is $\frac{20 \cdot \binom{20}{3,5,4,4,4}}{\binom{20}{4,4,4,4,4}} = 20 \cdot \frac{3!5!}{4!4!} = \mathbf{(E) 16}$

22. Inside a right circular cone with base radius 5 and height 12 are three congruent spheres each with radius r . Each sphere is tangent to the other two spheres and also tangent to the base and side of the cone. What is r ?

(A) $\frac{3}{2}$ (B) $\frac{90 - 40\sqrt{3}}{11}$ (C) 2 (D) $\frac{144 - 25\sqrt{3}}{44}$ (E) $\frac{5}{2}$

Solution (courtesy of tenebrine on AOPS): We will use coordinates. Let the center of the base of the cone be the origin O . Let V be the vertex of the cone, at $(0, 0, 12)$. WLOG suppose that one of the spheres has center N lying on $x = 0$. Note all 3 spheres have centers lying on $z = r$. Also, it's easy to see by symmetry that $(0, 0, r)$ is the centroid of the three spheres. Connecting the three spheres gives an equilateral triangle with sides $2r$, so by centroid ratios and 30-60-90 triangle N is at $(0, \frac{2r}{\sqrt{3}}, r)$. In fact the distance from N to the cone is equal to the distance from N to the plane $0x + 12y + 5z - 60 = 0$, which should be equal to r . Therefore, by Point-to-Plane, we have

$$\left| 8\sqrt{3}r + 5r - 60 \right| = 13r$$

It's clear r isn't very large, so $60 - (5 + 8\sqrt{3})r = 13r$. Simplifying gives

$$\frac{30}{9 + 4\sqrt{3}} = r$$

And rationalizing the denominator gives

$$r = \mathbf{(B) \frac{90 - 40\sqrt{3}}{11}}$$

23. For each positive integer n , let $f_1(n)$ be twice the number of positive integer divisors of n , and for $j \geq 2$, let $f_j(n) = f_1(f_{j-1}(n))$. For how many values of $n \leq 50$ is $f_{50}(n) = 12$?

(A) 7 (B) 8 (C) 9 (D) 10 (E) 11

Solution (from rayfish): 60, a highly composite number, has 12 divisors, so every number in $[1, 50]$ has at most 10 divisors. Testing all the even numbers from 2 to 20, we get that $f_1(12), f_1(18)$, and $f_1(20)$ cycle at 12, and all other values cycle at 8. Therefore, $d(n) = 6, 9$, or 10.

If $d(n) = 6$, then $n = p^5$ or p^2q . For the first case, the only number is $2^5 = 32$. For the second case, testing primes leads to 7 solutions. If $d(n) = 9$, the only number is $2^23^2 = 36$. If $d(n) = 10$, the only number is $2^43 = 48$.

Hence, the answer is $1 + 7 + 1 + 1 = \mathbf{(D) 10}$.

24. Each of the 12 edges of a cube is labeled 0 or 1. Two labelings are considered different even if one can be obtained from the other by a sequence of one or more rotations and/or reflections. For how many such labelings is the sum of the labels on the edges of each of the 6 faces of the cube equal to 2?

(A) 8 (B) 10 (C) 12 (D) 16 (E) 20

Solution (from FireLightning1876): We can label the opposite faces of the cube as red, black, or blue. We can use casework on this problem.

Case I: Two black 1s on the same face: 4 cases Without Loss of Generality, you can assume the black 1s are on the front face. Now, by trial and error, we can determine that the two red 1s are on the back face. Hence, the blue 1s are on opposite edges, giving 2 cases. By laws of multiplication, the number of cases is $4 * 2 = 8$

Case II: Two black 1s on opposite edges: 2 cases There are 2 cases for red 1s, in which they are on opposite edges or on the same face. In the first case, blue 1s should also be on opposite edges (2 cases), while in the second case, blue 1s are determined. So, the number of cases is $(2 * 2 * 2) + 4 = 12$.

In total, there are $8 + 12 = 20$ cases, so we get (E) 20

25. A quadratic polynomial $p(x)$ with real coefficients and leading coefficient 1 is called disrespectful if the equation $p(p(x)) = 0$ is satisfied by exactly three real numbers. Among all the disrespectful quadratic polynomials, there is a unique such polynomial $\tilde{p}(x)$ for which the sum of the roots is maximized. What is $\tilde{p}(1)$?

(A) $\frac{5}{16}$ (B) $\frac{1}{2}$ (C) $\frac{5}{8}$ (D) 1 (E) $\frac{9}{8}$

Solution (from datouci): Let the roots of the quadratic be r and s . The quadratic would be $p(x) = x^2 - (r + s)x + rs$.

$p(p(x)) = (x^2 - (r + s)x + rs)^2 - (r + s)(x^2 - (r + s)x + rs) + rs$. The solutions occur when $x^2 - (r + s)x + rs = r$ or $x^2 - (r + s)x + rs = s$. So:

$$x^2 - (r + s)x + rs - r = 0$$

$$x^2 - (r + s)x + rs - s = 0$$

One of these quadratic is a perfect square. WLOG let it be the first one. Then, $\Delta = 0$

$$(r + s)^2 - 4(rs - r) = 0$$

$$r^2 + 2rs + s^2 = 4rs - 4r$$

$$r^2 - 2rs + s^2 = -4r$$

$$(r - s)^2 = -4r$$

We want to maximize $r + s$ under the condition that $(r - s)^2 = -4r$. $r = -\frac{1}{4}$, $s = \frac{3}{4}$. The answer is

hence $(1 + \frac{1}{4})(1 - \frac{3}{4}) = \span style="border: 1px solid black; padding: 2px;">(A) \frac{5}{16}.$